

# PTR-PG16

Anti-vandal piezo switch PG16, recessed surface



The PTR-PG16 is a piezo-electric switch for use in rugged environments and anti-vandal applications. This switch is designed with a recessed surface for easy and secure location of the activation area. Ideal for applications where users work with gloves.

The PTR-PG16 is made of aviation grade aluminium or stainless steel and is fully customizable.

Ideal for use in food processing, parking meters, aviation, sanitary applications, pools & spa, clean rooms, oil & gas and self-service terminals.

## Key Characteristics

- ✓ No moving parts
- ✓ Activates with gloves and wet hands
- ✓ Rated at 50 million activations
- ✓ Washdown-proof up to 100 bar
- ✓ Shock proof (IK10)
- ✓ Reliable operation with snow and mud
- ✓ Fully waterproof (IP69K)
- ✓ No build-up of dirt or germs

## Product Options

- ❑ Switch diameter 16mm, 19mm, 22mm & 25mm
- ❑ Aluminium 6061 T651, stainless steel 303, 304 or 316
- ❑ Switch output (N.O. momentary, N.C. momentary, prolonged, toggle)
- ❑ Laser engraving or anodized printing
- ❑ Wire length, pins, terminal blocks

# PTR-PG16

Anti-vandal piezo switch PG16, recessed surface

## Electrical Data

---

Switch Function	N.O. Momentary (other functions optional)
Switch Voltage	0-24V AC/DC
Switch Current	0.2A Standard (up to 1 A optional)
Electrical Rating	1 Watt
Operating Cycles	> 50,000,000
Switch Resistance OFF	> 20M Ohm
Switch Resistance ON	< 5 Ohm
N.O. Impulse Duration	125ms (depending on force, time and speed)
Switch Capacitance	10 pF
Contact Configuration	Free Polarity

## Mechanical Data

---

Housing Materials	Aluminium 6061 T651 or stainless steel (303,/304/316)
Actuating Force	< 3 Newton
Connection	22 AWG standard (pin or terminal blocks optional)
Shock Protection	IK10
Mounting Screw Torque	2.5N

## Environmental Data

---

Operating Temperature	-20°C to 75°C
Storage Temperature	-40°C to 125°C
IP Protection	IP69K

# PTR-PG16

Anti-vandal piezo switch PG16, recessed surface

## Dimensional Drawing

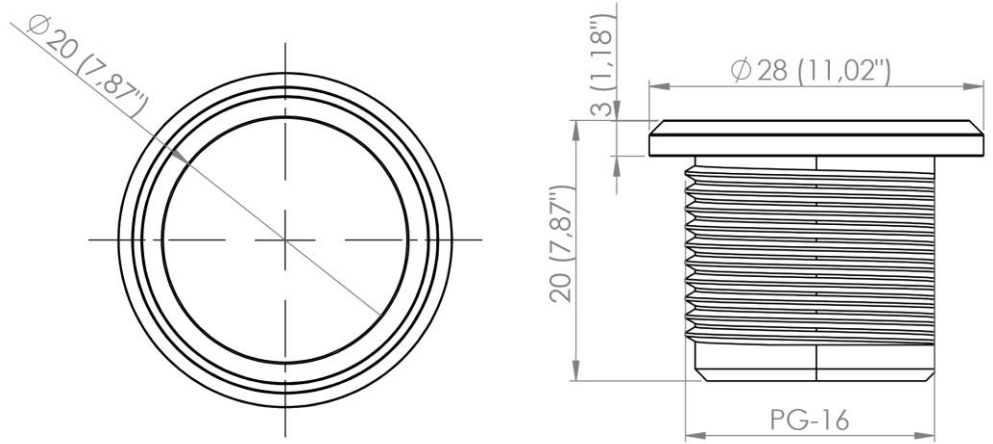

## Electrical Diagram

